



air-only / Wärmetauscher



water heater / Wasserwärmetauscher



electric wire heater / Elektroheizung



BASIC FEATURES

- Lengths: 1.0; 1.5; 2.0; 2.5 m
- **Air flow up to 5700 m³/h** (ISO 27 327-1)
- **Straw System** – maximized screening effect
- Universal interface for AirGENIO control module connection (BA, CO, SU)
- Low profile design
- Standard colour RAL 9016 (any RAL – based colours may be provided on customer's request)

The ESSENSSE NEO is low profile design air curtain for use in **retail shops, shopping centres, restaurants, administrative buildings and manufacturing facilities** with a recommended installation height up to 4 m.

The air curtain shall be installed indoors in a dry environment with ambient temperatures ranging from 0 °C up to +40 °C and relative humidity of up to 80 %. It is designed for conveying air free of fine dust, grease, chemical fumes, and other impurities. IP rating of the air curtain is IP 20. It is recommended that air curtain projects always be developed by an HVAC designer or engineer.



GRUNDEIGENSCHAFTEN

- Ausführungen in den Längen 1.0; 1.5; 2.0 und 2.5 m
- **Luftstrom bis zu 5700 m³/h** (ISO 27 327-1)
- **Straw System** – Maximierung des Abschirmungseffekts
- Universelle Schnittstelle für AirGENIO Steuerungsmodule (BA, CO, SU)
- Niedrige Einbauhöhe
- Farbe im Standard RAL 9016 (Farbliche Ausführung des Luftschleiers je nach Kundenwunsch)

Der ESSENSSE NEO ist Luftschleier für Anwendung in **Geschäften, Restaurants, Einkaufszentren, administrativen Gebäuden und Produktionshallen**, geeignet für Installationshöhe bis zu 4 m.

Der Luftschleier ist zum Betrieb in innerer, trockener Umgebung mit einer Umgebungstemperatur zwischen 0 °C bis +40 °C, mit relativer Luftfeuchtigkeit bis zu 80 % und zum Transport staubloser, fettloser Luft, die auch keine chemischen Dämpfe oder sonstige Verunreinigungen enthält vorgesehen. Der Luftschleier hat die Schutzart IP 20. Es wird empfohlen, dass Luftschleierprojekte immer durch einen HVAC-Fachmann durchgeführt werden.



PRIMARY PARAMETERS

Air curtains with electric heaters are equipped with an automatic heat thermostat and emergency thermostat with manual reset. Air curtains with LPHW coil are designed for a maximum operating water temperature of +130 °C and a maximum operating pressure of 1.6 MPa.



WICHTIGSTE PARAMETER

Die Luftschleier mit Elektrowärmetauscher sind mit einem Havariethermostat mit manuellem Reset ausgestattet. Die Warmwasserwärmetauscher sind für eine max. Betriebs-temperatur des Wassers +130 °C und max. Betriebsdruck 1,6 MPa bestimmt.

VCES2-B 50Hz

Type Typ	Recommended installation height [m] Empfohlene Installationshöhe [m]	Air output [m³/h] *1 Luftausstoß [m³/h] *1			Acoustic pressure at 3m [dB(A)]*2 Schalldruck in 3m [dB(A)]*2			Sound power [dB(A)]*3 Schalleistung [dB(A)]*3
		Speed 3 Geschwindigkeit 3	Speed 2 Geschwindigkeit 2	Speed 1 Geschwindigkeit 1	Speed 3 Geschwindigkeit 3	Speed 2 Geschwindigkeit 2	Speed 1 Geschwindigkeit 1	
VCES2 B 100-E0	3,2	1500	1000	650	53,8	48,9	43,3	71,3
VCES2 B 150-E0		2250	1650	1200	55,1	50,5	44,3	72,6
VCES2 B 200-E0		3300	2500	1900	56,8	48,6	41,9	74,3
VCES2 B 250-E0		3800	3000	2200	58,6	51,2	46,3	76,1
VCES2 B 100-E1		1500	1000	650	53,8	48,9	43,3	71,3
VCES2 B 150-E1		2250	1650	1200	55,1	50,5	44,3	72,6
VCES2 B 200-E1		3300	2500	1900	56,8	48,6	41,9	74,3
VCES2 B 250-E1		3800	3000	2200	58,6	51,2	46,3	76,1
VCES2 B 100-E2		1500	1000	650	53,8	48,9	43,3	71,3
VCES2 B 150-E2		2250	1650	1200	55,1	50,5	44,3	72,6
VCES2 B 200-E2		3300	2500	1900	56,8	48,6	41,9	74,3
VCES2 B 250-E2		3800	3000	2200	58,6	51,2	46,3	76,1
VCES2 B 100-V2		1500	1000	650	53,8	48,9	43,3	71,3
VCES2 B 150-V2		2250	1650	1200	55,1	50,5	44,3	72,6
VCES2 B 200-V2		3300	2500	1900	56,8	48,6	41,9	74,3
VCES2 B 250-V2		3800	3000	2200	58,6	51,2	46,3	76,1
VCES2 B 100-S0		1500	1000	650	53,8	48,9	43,3	71,3
VCES2 B 150-S0		2250	1650	1200	55,1	50,5	44,3	72,6
VCES2 B 200-S0		3300	2500	1900	56,8	48,6	41,9	74,3
VCES2 B 250-S0		3800	3000	2200	58,6	51,2	46,3	76,1

Type Typ	Heater power output [kW] Ausgangsleistung Heizgerät [kW]		Total power input [kW] Gesamtleistungsauf- nahme [kW]	Total voltage/ current [V/A] Gesamtspannung / Gesamtstrom [V/A]	Motor voltage/ current [V/A] Motorspannung / Motorstrom [V/A]	Temperature increase Δt [°C]*4 Temperaturanstieg Δt [°C]*4	Frequency [Hz] Frequenz der Stromversor- gung [Hz]	Weight [kg]*5 Gewicht [kg]*5
	1st level 1 St.	2nd level 2 St.						
VCES2 B 100-E0	3,2	4,7	4,9	400 / 13,8	230 / 0,7	9,3	50	25,5
VCES2 B 150-E0	3,8	7,5	7,7	400 / 11,9	230 / 1	9,9		32,6
VCES2 B 200-E0	4,8	9,5	9,8	400 / 15,4	230 / 1,3	8,6		39,8
VCES2 B 250-E0	6,9	12,2	12,6	400 / 19,4	230 / 1,6	9,6		46,9
VCES2 B 100-E1	3,2	6,3	6,5	400 / 13,8	230 / 0,7	13,2		25,5
VCES2 B 150-E1	5	10	10,2	400 / 21,8	230 / 1	13,3		32,6
VCES2 B 200-E1	6,3	12,6	12,9	400 / 27,5	230 / 1,3	12,0		39,8
VCES2 B 250-E1	8,2	16,3	16,6	400 / 26,2	230 / 1,6	13,1		46,9
VCES2 B 100-E2	4,7	9,5	9,7	400 / 14,5	230 / 0,7	19		25,7
VCES2 B 150-E2	7,5	15	15,2	400 / 22,8	230 / 1	20		32,9
VCES2 B 200-E2	9,5	19	19,3	400 / 29,1	230 / 1,3	17,2		40,3
VCES2 B 250-E2	12,2	24,5	25	400 / 37,1	230 / 1,6	19,3		47,5
VCES2 B 100-V2	16,9 *4	-	0,2	230 / 0,7	230 / 0,7	33,7		26,1
VCES2 B 150-V2	24,7 *4	-	0,2	230 / 1	230 / 1	32,9		32,9
VCES2 B 200-V2	35,7 *4	-	0,3	230 / 1,3	230 / 1,3	32,5		40,1
VCES2 B 250-V2	43,3 *4	-	0,4	230 / 1,6	230 / 1,6	34,2		47,4
VCES2 B 100-S0	-	-	0,2	230 / 0,7	230 / 0,7	-		24,8
VCES2 B 150-S0	-	-	0,2	230 / 1	230 / 1	-		31,3
VCES2 B 200-S0	-	-	0,3	230 / 1,3	230 / 1,3	-		38,3
VCES2 B 250-S0	-	-	0,4	230 / 1,6	230 / 1,6	-		45,1

*1 Airflow volume according ISO27327-1
 *2 Acoustic pressure values at 3 distance for maximum speed. Directional factor: Q=2.
 *3 Sound power (LWA) measurements according to ISO 27327-2.
 *4 Intake air temperature +18°C, at maximum heating level and highest fan speed.
 *5 Weight without controls.

*1 Luftvolumenstrom gemäß ISO27327-1
 *2 Schalldruck, gemessen in 3 m Entfernung vom Gerät bei maximaler Motorgeschwindigkeit. Richtungskoeffizient Q: 2.
 *3 Schalleistung (LWA) Messungen nach ISO 27327-2 Norm
 *4 Temperatur der angesaugten Luft +18°C bei maximaler Heizstufe und höchster Ventilatorgeschwindigkeit.
 *5 Gewicht ohne Regelung.



PRIMARY PARAMETERS

Air curtains with electric heaters are equipped with an automatic heat thermostat and emergency thermostat with manual reset. Air curtains with LPHW coil are designed for a maximum operating water temperature of +130 °C and a maximum operating pressure of 1.6 MPa.



WICHTIGSTE PARAMETER

Die Luftschleier mit Elektrowärmetauscher sind mit einem Havariethermostat mit manuellem Reset ausgestattet. Die Warmwasserwärmetauscher sind für eine max. Betriebstemperatur des Wassers +130 °C und max. Betriebsdruck 1,6 MPa bestimmt.

VCES2-B 60Hz

Type Typ	Recommended installation height [m] Empfohlene Installationshöhe [m]	Air output [m³/h] *1 Luftausstoß [m³/h] *1			Acoustic pressure at 3m [dB(A)]*2 Schalldruck in 3m [dB(A)]*2			Sound power [dB(A)]*3 Schallleistung [dB (A)]*3
		Speed 3 Geschwindigkeit 3	Speed 2 Geschwindigkeit 2	Speed 1 Geschwindigkeit 1	Speed 3 Geschwindigkeit 3	Speed 2 Geschwindigkeit 2	Speed 1 Geschwindigkeit 1	
VCES2 B 100-E0	3,2	1451	1021	828	60,2	53,6	52,4	77,7
VCES2 B 150-E0		2550	1899	1447	59,9	55,0	53,4	77,4
VCES2 B 200-E0		3811	2707	2149	64,1	57,3	55,7	81,6
VCES2 B 250-E0		4187	2679	2079	61,5	54,1	52,9	79,0
VCES2 B 100-E1		1451	1021	828	60,2	53,6	52,4	77,7
VCES2 B 150-E1		2550	1899	1447	59,9	55,0	53,4	77,4
VCES2 B 200-E1		3811	2707	2149	64,1	57,3	55,7	81,6
VCES2 B 250-E1		4187	2679	2079	61,5	54,1	52,9	79,0
VCES2 B 100-E2		1451	1021	828	60,2	53,6	52,4	77,7
VCES2 B 150-E2		2550	1899	1447	59,9	55,0	53,4	77,4
VCES2 B 200-E2		3811	2707	2149	64,1	57,3	55,7	81,6
VCES2 B 250-E2		4187	2679	2079	61,5	54,1	52,9	79,0
VCES2 B 100-V2		1457	1026	831	60,3	53,7	52,4	77,8
VCES2 B 150-V2		2562	1908	1453	60,0	55,1	53,5	77,5
VCES2 B 200-V2		3829	2719	2159	64,2	57,4	55,8	81,7
VCES2 B 250-V2		4206	2694	2088	61,6	54,2	53,0	79,1
VCES2 B 100-S0		1451	1021	828	60,2	53,6	52,4	77,7
VCES2 B 150-S0		2550	1899	1447	59,9	55,0	53,4	77,4
VCES2 B 200-S0		3811	2707	2149	64,1	57,3	55,7	81,6
VCES2 B 250-S0		4187	2679	2079	61,5	54,1	52,9	79,0

Type Typ	Heater power output [kW] Ausgangsleistung Heizgerät [kW]		Total power input [kW] Gesamtleistungsaufnahme [kW]	Total voltage/ current [V/A] Gesamtspannung / Gesamtstrom [V/A]	Motor voltage/ current [V/A] Motorspannung / Motorstrom [V/A]	Temperature increase Δt [°C]*4 Temperaturanstieg Δt [°C]*4	Frequency [Hz] Frequenz der Stromversorgung [Hz]	Weight [kg]*5 Gewicht [kg]*5
	1st level 1 St.	2nd level 2 St.						
VCES2 B 100-E0	3,2	4,7	4,9	400 / 13,8	230 / 0,8	9,3	60	25,5
VCES2 B 150-E0	3,8	7,5	7,8	400 / 11,9	230 / 1,3	9,9		32,6
VCES2 B 200-E0	4,8	9,5	10	400 / 15,4	230 / 2,2	8,6		39,8
VCES2 B 250-E0	6,9	12,2	12,8	400 / 19,4	230 / 2,6	9,6		46,9
VCES2 B 100-E1	3,2	6,3	6,5	400 / 13,8	230 / 0,8	13,2		25,5
VCES2 B 150-E1	5	10	10,3	400 / 21,8	230 / 1,3	13,3		32,6
VCES2 B 200-E1	6,3	12,6	13,1	400 / 27,5	230 / 2,2	12,0		39,8
VCES2 B 250-E1	8,2	16,3	16,9	400 / 26,2	230 / 2,6	13,1		46,9
VCES2 B 100-E2	4,7	9,5	9,7	400 / 14,5	230 / 0,8	19		25,7
VCES2 B 150-E2	7,5	15	15,3	400 / 22,8	230 / 1,3	20		32,9
VCES2 B 200-E2	9,5	19	19,5	400 / 29,1	230 / 2,2	17,2		40,3
VCES2 B 250-E2	12,2	24,5	25,1	400 / 37,1	230 / 2,6	19,3		47,5
VCES2 B 100-V2	16,9	-	0,2	230 / 0,8	230 / 0,8	33,7		26,1
VCES2 B 150-V2	24,7	-	0,3	230 / 1,3	230 / 1,3	32,9		32,9
VCES2 B 200-V2	35,7	-	0,5	230 / 2,2	230 / 2,2	32,5		40,1
VCES2 B 250-V2	43,3	-	0,6	230 / 2,6	230 / 2,6	34,2		47,4
VCES2 B 100-S0	-	-	0,2	230 / 0,8	230 / 0,8	-		24,8
VCES2 B 150-S0	-	-	0,3	230 / 1,3	230 / 1,3	-		31,3
VCES2 B 200-S0	-	-	0,5	230 / 2,2	230 / 2,2	-		38,3
VCES2 B 250-S0	-	-	0,6	230 / 2,6	230 / 2,6	-		45,1

*1 Airflow volume according ISO27327-1

*2 Acoustic pressure values at 3 m distance for maximum speed. Directional factor: Q=2.

*3 Sound power (LWA) measurements according to ISO 27327-2.

*4 Intake air temperature +18°C, at maximum heating level and highest fan speed.

*5 Weight without controls.

*1 Luftvolumenstrom gemäß ISO27327-1

*2 Schalldruck, gemessen in 3 m Entfernung vom Gerät bei maximaler Motorgeschwindigkeit. Richtungskoeffizient Q: 2.

*3 Schallleistung (LWA) Messungen nach ISO 27327-2 Norm

*4 Temperatur der angesaugten Luft +18°C bei maximaler Heizstufe und höchster Ventilatorgeschwindigkeit.

*5 Gewicht ohne Regelung.

VCES2-C

Type Typ	Recommended installation height [m] Empfohlene Installationshöhe [m]	Air output [m³/h] *1 Luftausstoß [m³/h] *1			Acoustic pressure at 3 m [dB(A)]*2 Schalldruck in 3 m [dB(A)]*2			Sound power [dB(A)]*3 Schalleistung [dB (A)]*3
		Speed 3 Geschwindigkeit 3	Speed 2 Geschwindigkeit 2	Speed 1 Geschwindigkeit 1	Speed 3 Geschwindigkeit 3	Speed 2 Geschwindigkeit 2	Speed 1 Geschwindigkeit 1	
VCES2 C 100-E1	4,0	2300	1750	1300	64,5	59,5	53,5	82
VCES2 C 150-E1		3200	2400	1600	65	60	54	82,5
VCES2 C 200-E1		4500	3500	2500	64	59	53	81,5
VCES2 C 250-E1		5700	4600	3500	64,2	59,2	53,2	81,7
VCES2 C 100-V2		2300	1750	1300	64,5	59,5	53,5	82
VCES2 C 150-V2		3200	2400	1600	65	60	54	82,5
VCES2 C 200-V2		4500	3500	2500	64	59	53	81,5
VCES2 C 250-V2		5700	4600	3500	64,2	59,2	53,2	81,7
VCES2 C 100-S0		2300	1750	1300	64,5	59,5	53,5	82
VCES2 C 150-S0		3200	2400	1600	65	60	54	82,5
VCES2 C 200-S0		4500	3500	2500	64	59	53	81,5
VCES2 C 250-S0		5700	4600	3500	64,2	59,2	53,2	81,7

Type Typ	Heater power output [kW] Ausgangsleistung Heizgerät [kW]		Total power input [kW] Gesamtleistungsaufnahme [kW]	Total voltage/ current [V/A] Gesamtspannung / Gesamtstrom [V/A]	Motor voltage/ current [V/A] Motorspannung / Motorstrom [V/A]	Temperature increase Δt [°C]*4 Temperaturanstieg Δt [°C]*4	Frequency [Hz] Frequenz der Stromversorgung [Hz]	Weight [kg]*5 Gewicht [kg]*5
	1st level 1 St.	2nd level 2 St.						
VCES2 C 100-E1	4,7	9,5	9,9	400 / 15,4	230 / 1,6	12,3	50	27,3
VCES2 C 150-E1	7,5	15,0	15,5	400 / 23,8	230 / 2	14,0		37,4
VCES2 C 200-E1	9,5	19,0	19,7	400 / 30,7	230 / 3	12,6		47,7
VCES2 C 250-E1	12,2	24,5	25,2	400 / 38,7	230 / 3,2	12,8		55,8
VCES2 C 100-V2	22,4		0,370	230 / 1,6	230 / 1,6	29,2		27,6
VCES2 C 150-V2	31,8		0,460	230 / 2	230 / 2	29,8		39,3
VCES2 C 200-V2	44,4		0,690	230 / 3	230 / 3	29,6		47,6
VCES2 C 250-V2	53,7		0,740	230 / 3,2	230 / 3,2	28,3		55,3
VCES2 C 100-S0	-	-	0,370	230 / 1,6	230 / 1,6	-		26,3
VCES2 C 150-S0	-	-	0,460	230 / 2	230 / 2	-		35,7
VCES2 C 200-S0	-	-	0,690	230 / 3	230 / 3	-		45,8
VCES2 C 250-S0	-	-	0,740	230 / 3,2	230 / 3,2	-		53,1

- *1 Airflow volume according ISO27327-1
- *2 Acoustic pressure values at 3 m distance for maximum speed. Directional factor: Q=2.
- *3 Sound power (LWA) measurements according to ISO 27327-2.
- *4 Intake air temperature +18°C, at maximum heating level and highest fan speed.
- *5 Weight without controls.

- *1 Luftvolumenstrom gemäß ISO27327-1
- *2 Schalldruck, gemessen in 3 m Entfernung vom Gerät bei maximaler Motorgeschwindigkeit. Richtungskoeffizient Q: 2.
- *3 Schalleistung (LWA) Messungen nach ISO 27327-2 Norm
- *4 Temperatur der angesaugten Luft +18°C bei maximaler Heizstufe und höchster Ventilatorgeschwindigkeit.
- *5 Gewicht ohne Regelung.

LPHW coil parameters for water temperature gradient
of 90/70 °C

Parameter des Wasserwärmetauschers bei einem
Wassertemperaturgradient 90/70 °C

Type Typ	Air output Luftausstoß	Heating output Heizausstoß	Temperature at exhaust Temperatur an Abluftöffnung	Pressure loss Druckverlust	Water flow Wasserdurchfluss
	[m³/h]	[kW]	[°C]	[kPa]	[l/s]
VCES2 B 100 V2	1500	16,85	51,7	13,93	0,2
VCES2 B 150 V2	2250	24,7	50,9	10,01	0,3
VCES2 B 200 V2	3300	35,74	50,5	14,52	0,43
VCES2 B 250 V2	3800	43,26	52,2	22,76	0,53
VCES2 C 100 V2	2300	22,35	47,2	23,25	0,27
VCES2 C 150 V2	3200	31,81	47,8	15,99	0,38
VCES2 C 200 V2	4500	44,41	47,6	21,78	0,54
VCES2 C 250 V2	5700	53,73	46,3	33,94	0,66

* Temperature of intake air: +18 °C / Ansauglufttemperatur + 18 °C

LPHW coil parameters for water temperature gradient
of 80/60 °C

Parameter des Wasserwärmetauschers bei einem
Wassertemperaturgradient 80/60 °C

Type Typ	Air output Luftausstoß	Heating output Heizausstoß	Temperature at exhaust Temperatur an Abluftöffnung	Pressure loss Druckverlust	Water flow Wasserdurchfluss
	[m³/h]	[kW]	[°C]	[kPa]	[l/s]
VCES2 B 100 V2	1500	14,1	46,2	10,3	0,17
VCES2 B 150 V2	2250	20,58	45,4	7,26	0,25
VCES2 B 200 V2	3300	29,79	45,1	10,59	0,36
VCES2 B 250 V2	3800	36,22	46,6	16,68	0,44
VCES2 C 100 V2	2300	18,59	42,2	16,97	0,23
VCES2 C 150 V2	3200	26,36	42,7	11,48	0,32
VCES2 C 200 V2	4500	36,93	42,6	15,79	0,45
VCES2 C 250 V2	5700	44,8	41,6	24,72	0,55

* Temperature of intake air: +18 °C / Ansauglufttemperatur + 18 °C

LPHW coil parameters for water temperature gradient of 70/50 °C

Parameter des Wasserwärmetauschers bei Wassertemperaturgradient 70/50 °C

Type Typ	Air output Luft-ausstoß	Heating output Heiz-austoß	Temperature at exhaust Temperatur an Abluftöffnung	Pressure loss Druck-verlust	Water flow Wasser-durchfluss
	[m³/h]	[kW]	[°C]	[kPa]	[l/s]
VCES2 B 100 V2	1500	11,23	40,5	6,97	0,14
VCES2 B 150 V2	2250	16,34	39,8	4,91	0,19
VCES2 B 200 V2	3300	23,65	39,5	6,97	0,28
VCES2 B 250 V2	3800	28,93	40,8	11,18	0,35
VCES2 C 100 V2	2300	14,74	37,2	11,38	0,18
VCES2 C 150 V2	3200	20,75	37,5	7,55	0,25
VCES2 C 200 V2	4500	29,14	37,4	10,3	0,35
VCES2 C 250 V2	5700	35,62	36,7	16,38	0,43

* Temperature of intake air: +18 °C / Ansauglufttemperatur + 18 °C

LPHW coil parameters for water temperature gradient of 60/40 °C

Parameter des Wasserwärmetauschers bei Wassertemperaturgradient 60/40 °C

Type Typ	Air output Luft-ausstoß	Heating output Heiz-austoß	Temperature at exhaust Temperatur an Abluftöffnung	Pressure loss Druck-verlust	Water flow Wasser-durchfluss
	[m³/h]	[kW]	[°C]	[kPa]	[l/s]
VCES2 B 100 V2	1500	8,27	34,5	4,12	0,1
VCES2 B 150 V2	2250	11,86	33,8	2,75	0,14
VCES2 B 200 V2	3300	17,26	33,7	4,02	0,2
VCES2 B 250 V2	3800	21,33	34,8	6,47	0,26
VCES2 C 100 V2	2300	10,71	32,0	6,57	0,13
VCES2 C 150 V2	3200	14,97	32,0	4,22	0,18
VCES2 C 200 V2	4500	21,06	32,0	5,79	0,25
VCES2 C 250 V2	5700	26,03	31,7	9,42	0,31

* Temperature of intake air: +18 °C / Ansauglufttemperatur + 18 °C

Recommended mixing points for LPHW coil 2-way valve

Empfohlen für den Wasserventil des Wasserwärmetauschers 2-Wege-Ventil

Type Typ	Control module Steuerungsmodul	90/70 °C	80/60 °C	70/50 °C	60/40 °C
		2-way valve 2-Wege-Ventil			
VCES2 B 100 V2	RGJ-VCES2-BA	ZV2-230-08,0-20	ZV2-230-08,0-20	ZV2-230-08,0-20	ZV2-230-08,0-20
	RGJ3-VCES2-CO	ZV2-230-08,0-20	ZV2-230-08,0-20	ZV2-230-08,0-20	ZV2-230-08,0-20
	RGJ3-VCES2-SU	ZV2-024-08,0-20	ZV2-024-08,0-20	ZV2-024-08,0-20	ZV2-024-08,0-20
VCES2 B 150 V2	RGJ-VCES2-BA	ZV2-230-08,0-20	ZV2-230-08,0-20	ZV2-230-08,0-20	ZV2-230-08,0-20
	RGJ3-VCES2-CO	ZV2-230-08,0-20	ZV2-230-08,0-20	ZV2-230-08,0-20	ZV2-230-08,0-20
	RGJ3-VCES2-SU	ZV2-024-08,0-20	ZV2-024-08,0-20	ZV2-024-08,0-20	ZV2-024-08,0-20
VCES2 B 200 V2	RGJ-VCES2-BA	ZV2-230-08,0-20	ZV2-230-08,0-20	ZV2-230-08,0-20	ZV2-230-08,0-20
	RGJ3-VCES2-CO	ZV2-230-08,0-20	ZV2-230-08,0-20	ZV2-230-08,0-20	ZV2-230-08,0-20
	RGJ3-VCES2-SU	ZV2-024-08,0-20	ZV2-024-08,0-20	ZV2-024-08,0-20	ZV2-024-08,0-20
VCES2 B 250 V2	RGJ-VCES2-BA	ZV2-230-21,0-20	ZV2-230-08,0-20	ZV2-230-08,0-20	ZV2-230-08,0-20
	RGJ3-VCES2-CO	ZV2-230-21,0-20	ZV2-230-08,0-20	ZV2-230-08,0-20	ZV2-230-08,0-20
	RGJ3-VCES2-SU	ZV2-024-16,0-25	ZV2-024-08,0-20	ZV2-024-08,0-20	ZV2-024-08,0-20
VCES2 C 100 V2	RGJ-VCES2-BA	ZV2-230-08,0-20	ZV2-230-08,0-20	ZV2-230-08,0-20	ZV2-230-08,0-20
	RGJ3-VCES2-CO	ZV2-230-08,0-20	ZV2-230-08,0-20	ZV2-230-08,0-20	ZV2-230-08,0-20
	RGJ3-VCES2-SU	ZV2-024-08,0-20	ZV2-024-08,0-20	ZV2-024-08,0-20	ZV2-024-08,0-20
VCES2 C 150 V2	RGJ-VCES2-BA	ZV2-230-08,0-20	ZV2-230-08,0-20	ZV2-230-08,0-20	ZV2-230-08,0-20
	RGJ3-VCES2-CO	ZV2-230-08,0-20	ZV2-230-08,0-20	ZV2-230-08,0-20	ZV2-230-08,0-20
	RGJ3-VCES2-SU	ZV2-024-08,0-20	ZV2-024-08,0-20	ZV2-024-08,0-20	ZV2-024-08,0-20
VCES2 C 200 V2	RGJ-VCES2-BA	ZV2-230-21,0-20	ZV2-230-08,0-20	ZV2-230-08,0-20	ZV2-230-08,0-20
	RGJ3-VCES2-CO	ZV2-230-21,0-20	ZV2-230-08,0-20	ZV2-230-08,0-20	ZV2-230-08,0-20
	RGJ3-VCES2-SU	ZV2-024-16,0-25	ZV2-024-08,0-20	ZV2-024-08,0-20	ZV2-024-08,0-20
VCES2 C 250 V2	RGJ-VCES2-BA	ZV2-230-21,0-20	ZV2-230-08,0-20	ZV2-230-08,0-20	ZV2-230-08,0-20
	RGJ3-VCES2-CO	ZV2-230-21,0-20	ZV2-230-08,0-20	ZV2-230-08,0-20	ZV2-230-08,0-20
	RGJ3-VCES2-SU	ZV2-024-16,0-25	ZV2-024-08,0-20	ZV2-024-08,0-20	ZV2-024-08,0-20

Recommended mixing points for LPHW coil 3-way valve

Empfohlen für den Wasserventil des
Wasserwärmetauschers 3-Wege-Ventil

Type Typ	Control module Steuerungsmodul	90/70 °C	80/60 °C	70/50 °C	60/40 °C
		3-way valve 3-Wege-Ventil			
VCES2 B 100 V2	RGJ-VCES2-BA	ZV3-230-04,0-20	ZV3-230-04,0-20	ZV3-230-04,0-20	ZV3-230-04,0-20
		RT-3-07	RT-3-07	RT-3-07	RT-3-07
	RGJ3-VCES2-CO	ZV3-230-04,0-20	ZV3-230-04,0-20	ZV3-230-04,0-20	ZV3-230-04,0-20
		RT-3-07	RT-3-07	RT-3-07	RT-3-07
RGJ3-VCES2-SU	ZV3-024-04,0-20	ZV3-024-04,0-20	ZV3-024-04,0-20	ZV3-024-04,0-20	
VCES2 B 150 V2	RGJ-VCES2-BA	ZV3-230-21,0-20	ZV3-230-04,0-20	ZV3-230-04,0-20	ZV3-230-04,0-20
		RT-3-07	RT-3-07	RT-3-07	RT-3-07
	RGJ3-VCES2-CO	ZV3-230-04,0-20	ZV3-230-04,0-20	ZV3-230-04,0-20	ZV3-230-04,0-20
		RT-3-07	RT-3-07	RT-3-07	RT-3-07
RGJ3-VCES2-SU	ZV3-024-06,3-20	ZV3-024-04,0-20	ZV3-024-04,0-20	ZV3-024-04,0-20	
VCES2 B 200 V2	RGJ-VCES2-BA	ZV3-230-21,0-20	ZV3-230-21,0-20	ZV3-230-21,0-20	ZV3-230-04,0-20
		RT-3-07	RT-3-07	RT-3-07	RT-3-07
	RGJ3-VCES2-CO	ZV3-230-21,0-20	ZV3-230-21,0-20	ZV3-230-21,0-20	ZV3-230-04,0-20
		RT-3-07	RT-3-07	RT-3-07	RT-3-07
RGJ3-VCES2-SU	ZV3-024-06,3-20	ZV3-024-06,3-20	ZV3-024-06,3-20	ZV3-024-04,0-20	
VCES2 B 250 V2	RGJ-VCES2-BA	ZV3-230-21,0-20	ZV3-230-21,0-20	ZV3-230-21,0-20	ZV3-230-04,0-20
		RT-3-07	RT-3-07	RT-3-07	RT-3-07
	RGJ3-VCES2-CO	ZV3-230-21,0-20	ZV3-230-21,0-20	ZV3-230-21,0-20	ZV3-230-04,0-20
		RT-3-07	RT-3-07	RT-3-07	RT-3-07
RGJ3-VCES2-SU	ZV3-024-10,0-25	ZV3-024-06,3-20	ZV3-024-06,3-20	ZV3-024-04,0-20	
VCES2 C 100 V2	RGJ-VCES2-BA	ZV3-230-21,0-20	ZV3-230-04,0-20	ZV3-230-04,0-20	ZV3-230-04,0-20
		RT-3-07	RT-3-07	RT-3-07	RT-3-07
	RGJ3-VCES2-CO	ZV3-230-21,0-20	ZV3-230-04,0-20	ZV3-230-04,0-20	ZV3-230-04,0-20
		RT-3-07	RT-3-07	RT-3-07	RT-3-07
RGJ3-VCES2-SU	ZV3-024-06,3-20	ZV3-024-04,0-20	ZV3-024-04,0-20	ZV3-024-04,0-20	
VCES2 C 150 V2	RGJ-VCES2-BA	ZV3-230-21,0-20	ZV3-230-21,0-20	ZV3-230-04,0-20	ZV3-230-04,0-20
		RT-3-07	RT-3-07	RT-3-07	RT-3-07
	RGJ3-VCES2-CO	ZV3-230-21,0-20	ZV3-230-21,0-20	ZV3-230-04,0-20	ZV3-230-04,0-20
		RT-3-07	RT-3-07	RT-3-07	RT-3-07
RGJ3-VCES2-SU	ZV3-024-06,3-20	ZV3-024-06,3-20	ZV3-024-04,0-20	ZV3-024-04,0-20	
VCES2 C 200 V2	RGJ-VCES2-BA	ZV3-230-21,0-20	ZV3-230-21,0-20	ZV3-230-21,0-20	ZV3-230-04,0-20
		RT-3-07	RT-3-07	RT-3-07	RT-3-07
	RGJ3-VCES2-CO	ZV3-230-21,0-20	ZV3-230-21,0-20	ZV3-230-21,0-20	ZV3-230-04,0-20
		RT-3-07	RT-3-07	RT-3-07	RT-3-07
RGJ3-VCES2-SU	ZV3-024-10,0-25	ZV3-024-06,3-20	ZV3-024-06,3-20	ZV3-024-04,0-20	
VCES2 C 250 V2	RGJ-VCES2-BA	ZV3-230-21,0-20	ZV3-230-21,0-20	ZV3-230-21,0-20	ZV3-230-21,0-20
		RT-3-07	RT-3-07	RT-3-07	RT-3-07
	RGJ3-VCES2-CO	ZV3-230-21,0-20	ZV3-230-21,0-20	ZV3-230-21,0-20	ZV3-230-21,0-20
		RT-3-07	RT-3-07	RT-3-07	RT-3-07
RGJ3-VCES2-SU	ZV3-024-10,0-25	ZV3-024-10,0-25	ZV3-024-06,3-20	ZV3-024-06,3-20	

MAIN PARTS

HAUPTTEILE

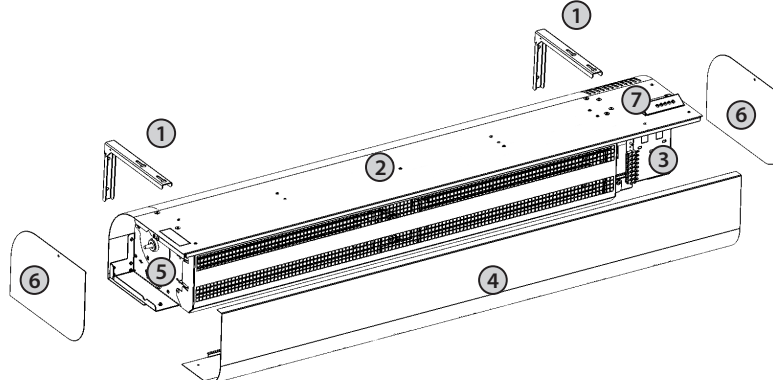

- ① Mounting brackets (**included with delivery**)
- ② Top cover
- ③ Connection dock for controls module
- ④ Intake grill
- ⑤ Connection dock for LPHW (only on water versions)
- ⑥ Side cover
- ⑦ Main power supply connection

- ① Montagehalterungen (**im Lieferumfang enthalten**)
- ② Obere Abdeckung
- ③ Bereich für den Anschluss des Regelungsmoduls
- ④ Saugabdeckung
- ⑤ Anschluss für den Wasserwärmetauscher (nur an Wasserversionen)
- ⑥ Seitenabdeckung
- ⑦ Hauptstromversorgung Anschlusspunkt



INSTALLATION AND ASSEMBLY

- The air curtain must be installed in a horizontal position only.
- The air curtain shall be located as close as possible to the top edge of the doorway, and a distance from walls that is in accordance with fire safety and building codes of the country where unit is installed. For manufacturer recommended distance see figures below.
- To ensure proper function it is recommended that the air curtain overlaps the doorway by 100 mm on both sides.
- Correct operation of the air curtain requires that specified distances from the surrounding objects are observed, see figure.
- Please take note of water and power supply connections when installing air curtain.
- The air curtain shall be installed using supplied brackets.

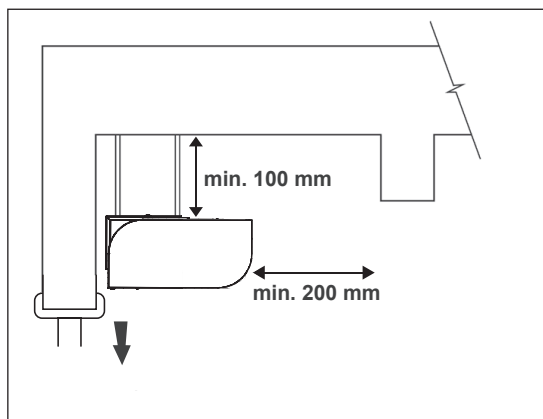

INSTALLATION UND MONTAGE

- Der Luftschiefer kann nur in horizontaler Lage installiert werden
- Der Luftschiefer ist so nah wie möglich zur oberen Kante der Türöffnung anzubringen, in Abhängigkeit von Brandvorschriften in gegebenem Land, siehe Abb.
- für die richtige Funktion wird empfohlen, den Luftschiefer auf jeder Seite um 100mm breiter als die Türöffnung zu haben
- für die richtige Funktion des Luftschiefers sind die Abstandsentfernungen des Luftschiefers, siehe Abbildung, zu beachten
- bei der Installation muss die Schaltung des Luftschiefers auf die Warmwasser- und Stromzuführung berücksichtigt werden
- Zum Aufhängen des Luftschiefers werden beigegefügte Halterungen verwendet.

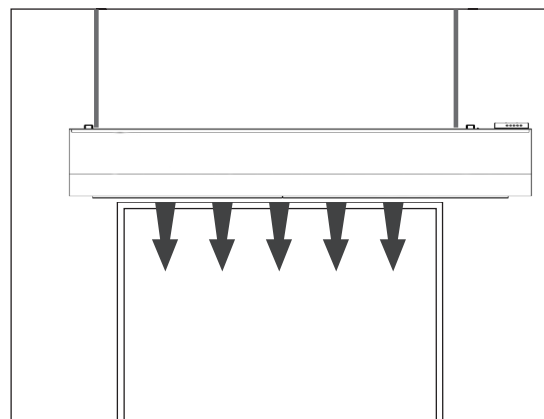

Air curtain dimensions
Abmessungen des Luftschleiers

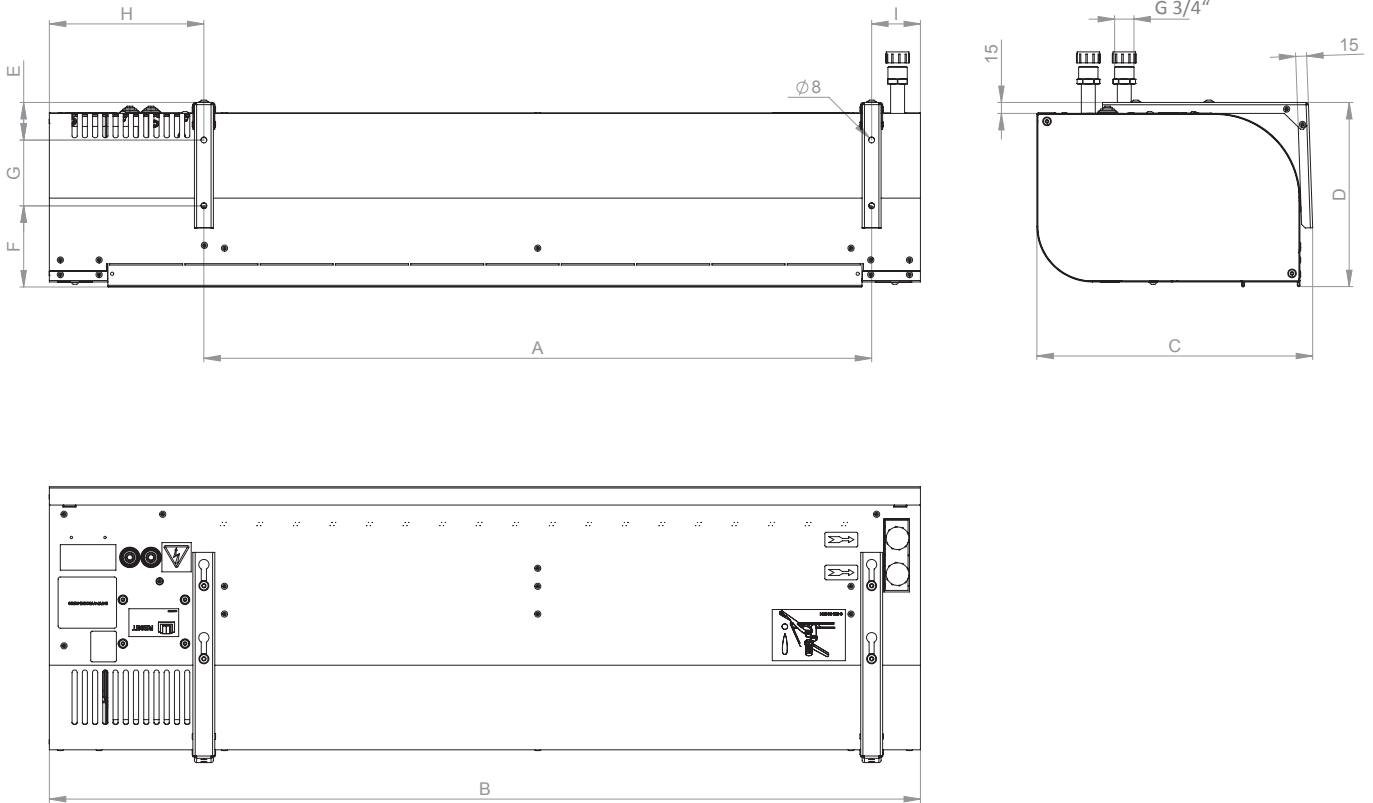

Type Typ	A	B	C	D	E	F	G	H	I
VCES2 B 100	913	1190	377	252	51	111	90	211	67
VCES2 C 100	913	1190	377	252	51	111	90	211	67
VCES2 B 150	1321	1600	377	252	51	111	90	211	67
VCES2 C 150	1321	1600	377	252	51	111	90	211	67
VCES2 B 200	1822	2100	377	252	51	111	90	211	67
VCES2 C 200	1822	2100	377	252	51	111	90	211	67
VCES2 B 250	2232	2510	377	252	51	111	90	211	67
VCES2 C 250	2232	2510	377	252	51	111	90	211	67



CONTROL

Overview of functions and sensor connections



STEUERUNG

Übersicht der Funktionen und Sensoranschlüsse



AirGENIO control		BASIC RGJ-VCES2-BA	COMFORT RGJ3-VCES2-CO	SUPERIOR RGJ3-VCES2-SU
	Type of controller Steuerungstyp	Manual Manuell	Touch screen Touch-screen	Touch screen Touch-screen
	Mode Modus	Manual Manuell	Manual / Auto Manuell / Automatisch	Manual / Auto Manuell / Automatisch
	Control of air output Steuerung des Luftausstoßes	3 speeds 3 Geschwindigkeiten	3 speeds 3 Geschwindigkeiten	3 speeds (AC) 3 Geschwindigkeiten (AC)
	Control of electric heater Steuerung des Elektrowärmetauschers	OFF / Level1 / Level2 AUS / Stufe 1 / Stufe 2	OFF / Level1 / Level2 AUS / Stufe 1 / Stufe 2	YES (PWM) JA (PWM)
	Control of water heater Steuerung des Wasserwärmetauschers	ON/OFF AN/AUS	ON/OFF AN/AUS	0-10V 0-10V
	Antifreeze protection of LPHW Frostfreihaltung des Wasserwärmetauschers	NO NEIN	YES JA	YES JA
	Possibility of connecting a door contact Türkontakt anschliessbar	YES (230V) JA (230V)	YES (12V) JA (12V)	YES (12V) JA (12V)
	External control Externbedienung	NO NEIN	YES JA	YES JA
	Temperature measurement Temperaturmessung	NO NEIN	YES (NTC)* Ja (NTC)*	YES (NTC)* Ja (NTC)*
	Chaining air curtains Luftschleierverkettung	NO NEIN	YES – max 10+1 pcs JA – max 10+1 Stk.	YES – max 10+1 pcs JA – max 10+1 Stk.
	Indication of selected function Anzeige der gewählten Funktion	YES JA	YES (Display) JA (Anzeige)	YES (Display) JA (Anzeige)
	Controller connection to air curtain Verbindung des Steuergerätes mit dem Luftschleier	Power wire Stromkabel	Communication cable (UTP) Kommunikationskabel (UTP)	Communication cable (UTP) Kommunikationskabel (UTP)
	Self learning mode Selbstlernmodus	NO NEIN	NO NEIN	YES JA
	BMS connection BMS-Anschluss	NO NEIN	Modbus RTU	Modbus RTU, Modbus TCP, BACnet
	Error contact Fehlerkontakt	NO NEIN	YES JA	YES JA
	2 nd control panel ready 2. Bedienelement bereit	NO NEIN	YES JA	YES JA

^{*)} Temperature sensor included in standard. Temperature shown on display.

^{*)}Temperatursensor ist standardmäßig inbegriffen. Temperatur wird am Display angezeigt.



Chaining example

COMFORT / SUPERIOR

Global Door contact function active

Vordere-Türkontakt ist aktiv

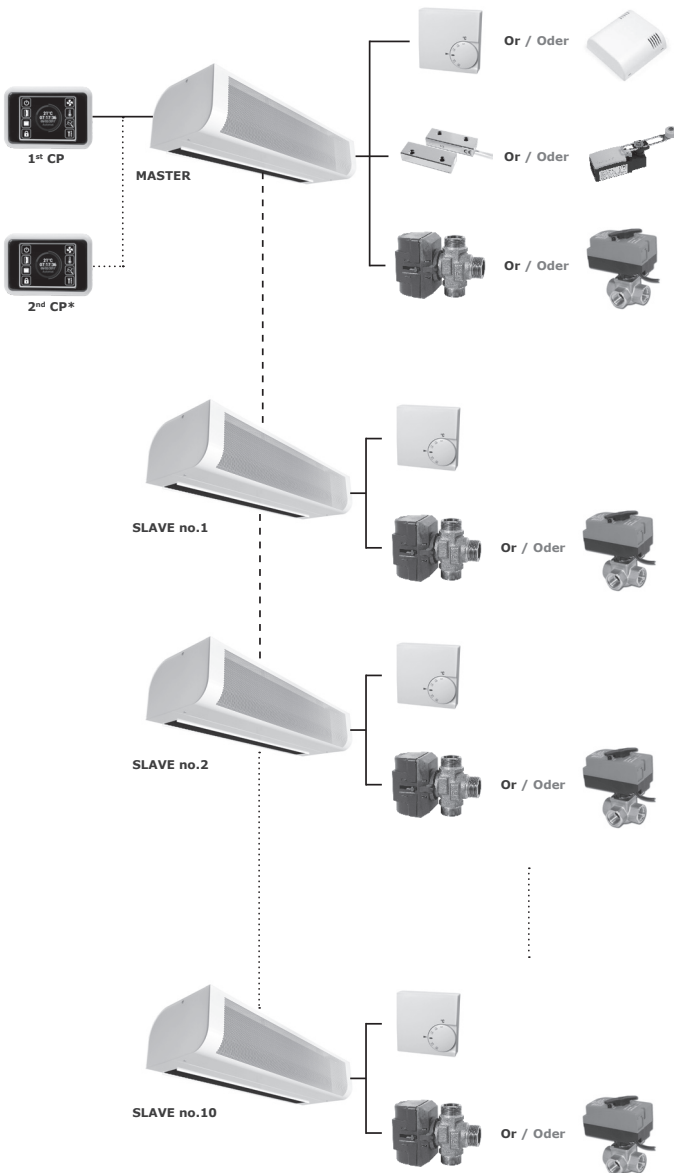

*) Optional accessories



Verkettungsbeispiel

COMFORT / SUPERIOR

Global Door contact function not active

Vordere-Türkontakt ist nicht aktiv

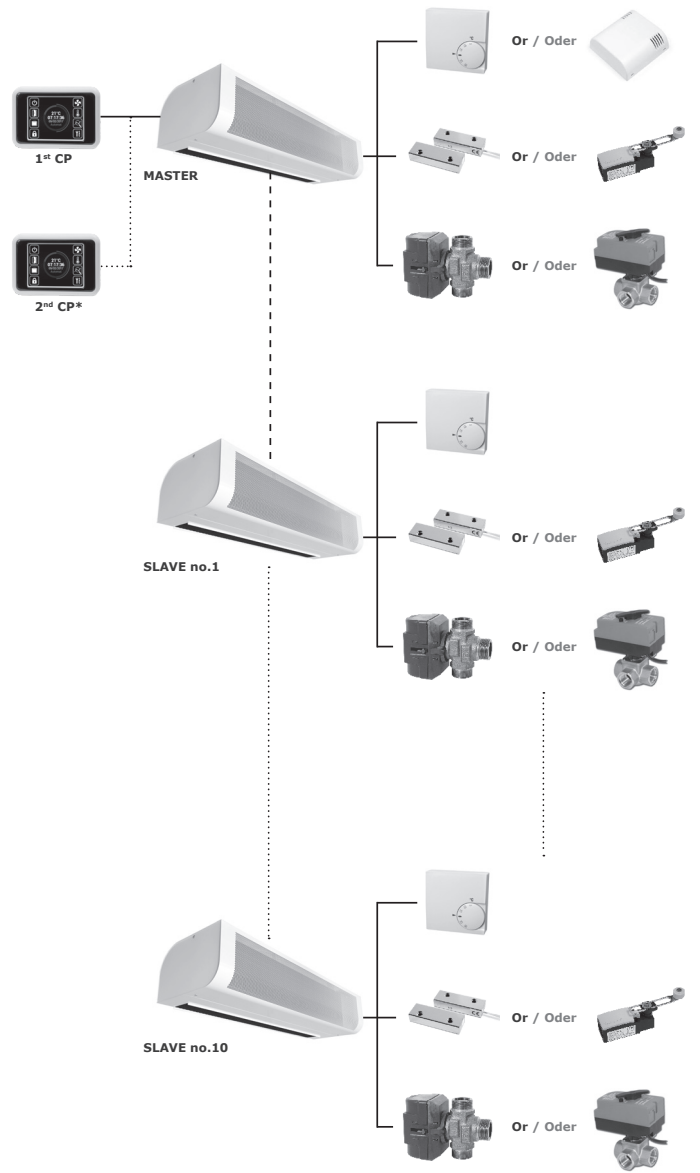

*) Optionales Zubehör



ACCESSORIES

REQUIRED ACCESSORIES

These accessories are required to make the curtain functional.

AirGENIO Control module

A control module is a required accessory for ESSENSSE NEO air curtain and are required for each air curtain.

A control panel is included in the delivery with the control module. The ordering key for control modules is provided below. The control panel of Basic control module is connected using common wiring cable (230 V control voltage). A suitable cross-section of the cable shall be determined based on the particular installation conditions. This cable should be provided by a company performing the air curtain electrical wiring. The control panel of Comfort/Superior module is connected using UTP communication cable (not included).



ZUBEHÖR

ERFORDERLICHES ZUBEHÖR

Dieses Zubehör muss bestellt werden, damit der Luftschiefer funktionsfähig ist.

AirGENIO Steuerungsmodul

Ein Steuerungsmodul ist ein obligatorisches Zubehörteil für den Luftschiefer ESSENSSE NEO und muss für einzelne Luftschiefer bestellt werden. Die Schalttafel ist im Lieferumfang des Steuerungsmoduls enthalten. Die Bestellnummern für die Steuerungsmodule sind weiter unten angegeben.

Die Schalttafel des Basic-Steuerungsmoduls wird über ein übliches Elektrokabel angeschlossen (Spannung 230 V). Die geeignete Kabelgröße muss anhand der jeweiligen Installationsbedingungen gewählt werden. Dieses Kabel soll von der Firma geliefert werden, die die elektrische Installation des Luftschiefers durchführt.

Comfort/Superior-Modul Verwendung UTP Kommunikation Kabel (ist nicht enthalten).

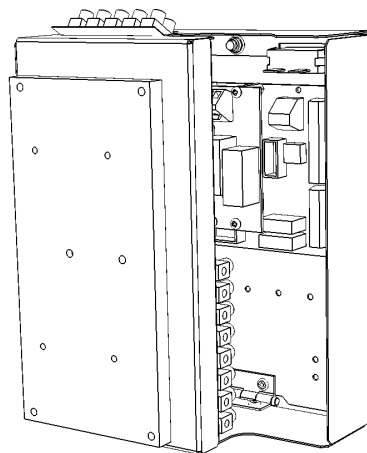

RGJ3-VCES2-SU-E-MA-1-AC

- AC – AC motor
- 1 – only for E versions, air curtain length 100, 150
- 2 – only for E versions, air curtain length 200, 250
- SL – SLAVE (only for CO, SU)
- MA – MASTER (only for CO, SU)
- S – without heating regulation
- E – with electric heater regulation
- V – with water heater regulation
- BA – Basic control (mechanical)
- CO – Comfort control (touch screen)
- SU – Superior control (touch screen)
- VCES2 – air curtain Essensse NEO
- RGJ – Controls (BA)
- RGJ3 – Controls (CO, SU)

RGJ3-VCES2-SU-E-MA-1-AC

- AC – AC Lüfter
- 1 – nur für E version, Luftschiefer länge 100, 150
- 2 – nur für E version, Luftschiefer länge 200, 250
- SL – SLAVE (nur für CO, SU)
- MA – MASTER (nur für CO, SU)
- S – ohne Heizgerätregelung
- E – mit Regelung von Elektroheizgeräten
- V – mit Regelung von Wasserheizgeräten
- BA – Basic (manuelle Steuerung)
- CO – Comfort (touch screen Steuerung)
- SU – Superior (touch screen Steuerung)
- VCES2 – Luftschiefer Essensse NEO
- RGJ – Regelung (BA)
- RGJ3 – Regelung (CO, SU)

OPTIONAL ACCESSORIES

More details can be found on the relevant page in this catalogue

2-way Thermostatic valve TV-1-1/1
TV-1-1/1



2-way or 3-way valve with servo drive (230V)
ZV2-230-xx,x-xx
ZV3-230-xx,x-xx
(for control BA, CO)



3-way valve with servo drive RT
RT-3-07 (K_{vs} 7)
(for control BA, CO)



2way or 3-way valve with servo drive (0-10V)
ZV2-024-xx,x-xx
ZV3-024-xx,x-xx
(for control SU)



Mixing node
SMU2-230-xx (for control BA, CO)
SMU2-024-xx (for control SU)



Room thermostat
TER-P



Room temperature sensor
CT-ROOM (for control SU)



OPTIONALES ZUBEHÖR

Weitere Details finden Sie auf der entsprechenden Seite in diesem Katalog

2-Wege-Thermostatventil TV-1-1/1
TV-1-1/1

2-Wege oder 3-Wege-Ventil mit Servoantrieb (230V)
ZV2-230-xx,x-xx
ZV3-230-xx,x-xx
(für Steuerung BA, CO)

3-Wege-Ventil mit Servoantrieb RT
RT-3-07 (K_{vs} 07)
(für Steuerung BA, CO)

2-Wege oder 3-Wege-Ventil mit Servoantrieb (0-10V)
ZV2-024-xx,x-xx
ZV3-024-xx,x-xx
(für Steuerung SU)

Mischknoten
SMU2-230-xx (für Steuerung BA, CO)
SMU2-024-xx (für Steuerung SU)

Raumthermostat
TER-P

Raumsensor
CT-ROOM (für Steuerung SU)

Mechanical door switch (230V)
DS



Mechanischer Türkontaktschalter (230V)
DS

Magnetic door contact (12V)
DK-1





Magnetischer Türkontaktschalter (12V)
DK-1

Magnetic door contact (12V) in a metal housing
with higher protection against mechanical damage
DK-B-3



Magnetischer Türkontaktschalter (12V) in einem
Metallgehäuse mit höheren Schutz vor mechanischer
Beschädigung
DK-B-3

	BASIC RGJ-VCES2-BA	COMFORT RGJ3-VCES2-CO	SUPERIOR RGJ3-VCES2-SU
	✓	✓*	✓*
	✗	✓	✓
	✗	✓	✓

* Recommended for industry use

* Empfohlen für den Industriebereich

OpenEnd module (Control module for BMS)
OE-M-AC3 (for control BA)

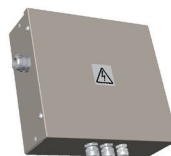

OpenEnd Modul (Steuermodul für BMS)
OE-M-AC3 (für Steuerung BA)

2nd Control panel
ND-REMOTE-CONTROL (for control CO, SU)



2. Bedienelement
ND-REMOTE-CONTROL (für Steuerung CO, SU)



WIRING DIAGRAMS

The recommended cross-section of the main power supply cables is stated in the Instruction Manual.

All wiring diagrams provided in the technical catalog are indicative only. When assembling the product, carefully observe the nameplate ratings as well as directions and diagrams affixed directly to the product or enclosed with the product.



SCHALTPLÄNE

Empfohlene Dimensionierung der Hauptstromversorgung - Kabeln befindet sich in der Anleitung.

Sämtliche, im Katalog aufgeführten, Schaltpläne sind nur informativ. Bei der Montage des Produktes richten Sie sich ausschließlich nach den Schild-werten und Schaltplänen, die entweder auf dem Produkt angebracht sind oder dem Produkt beigelegt sind.



AirGENIO BASIC

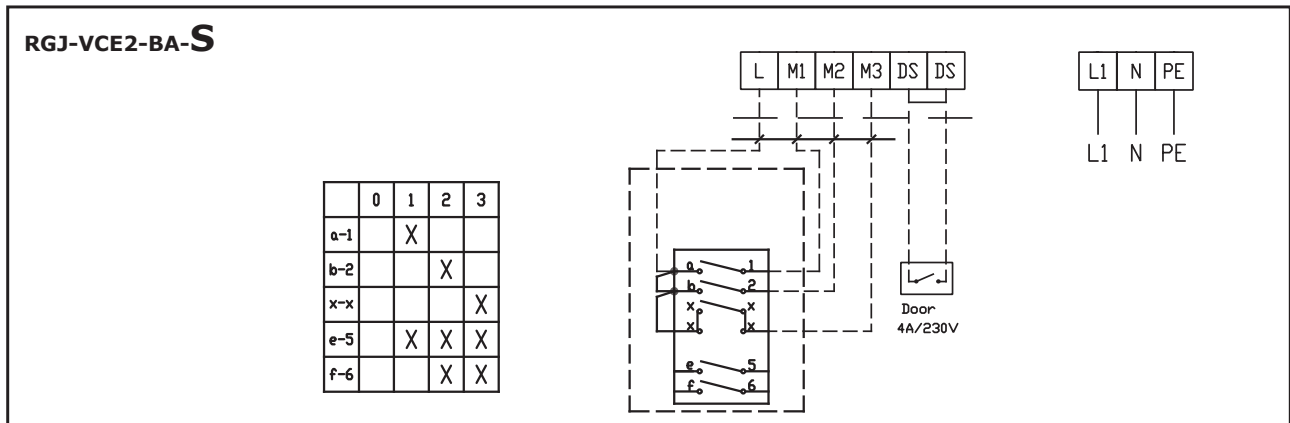
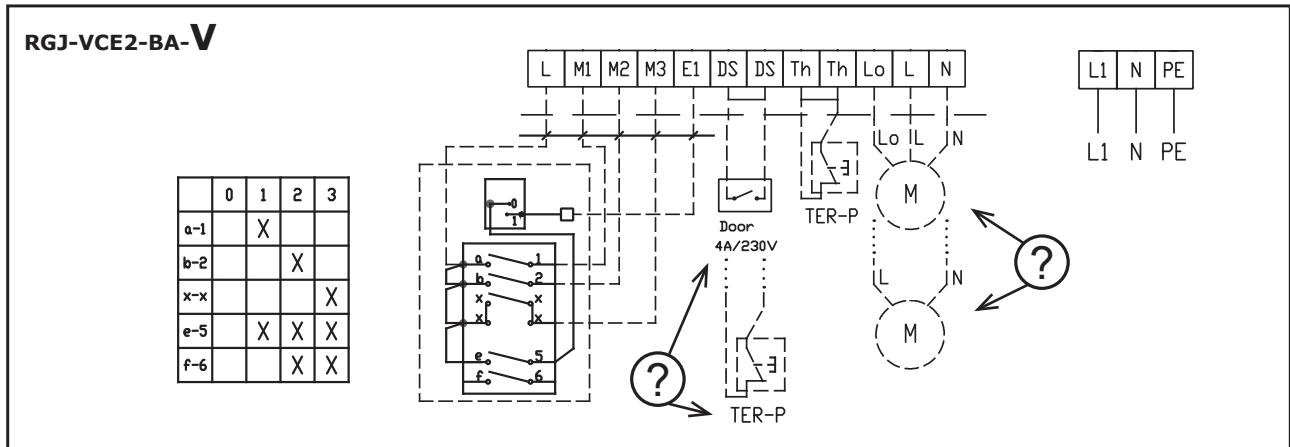
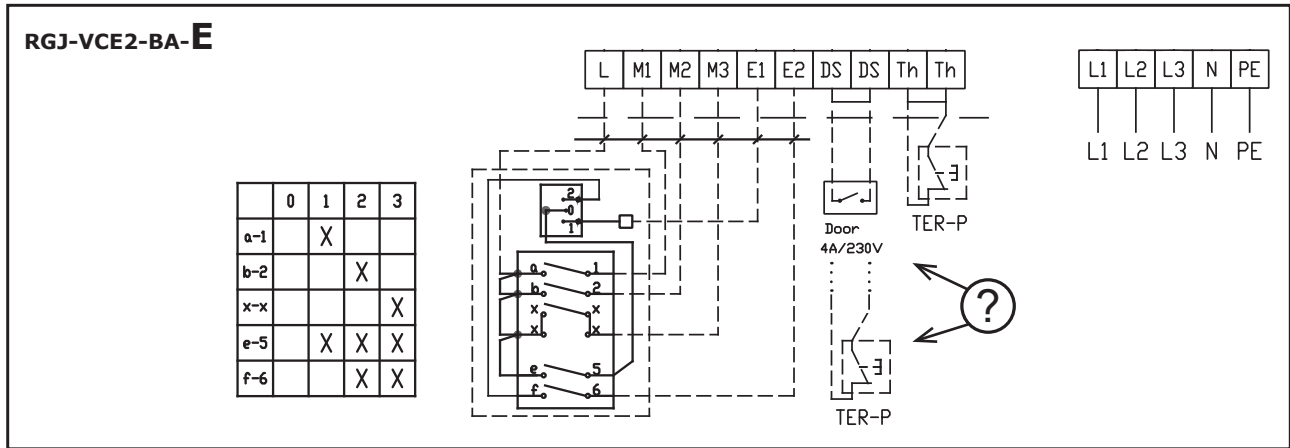

WIRING DIAGRAMS

SCHALTPLÄNE



AirGENIO COMFORT MASTER

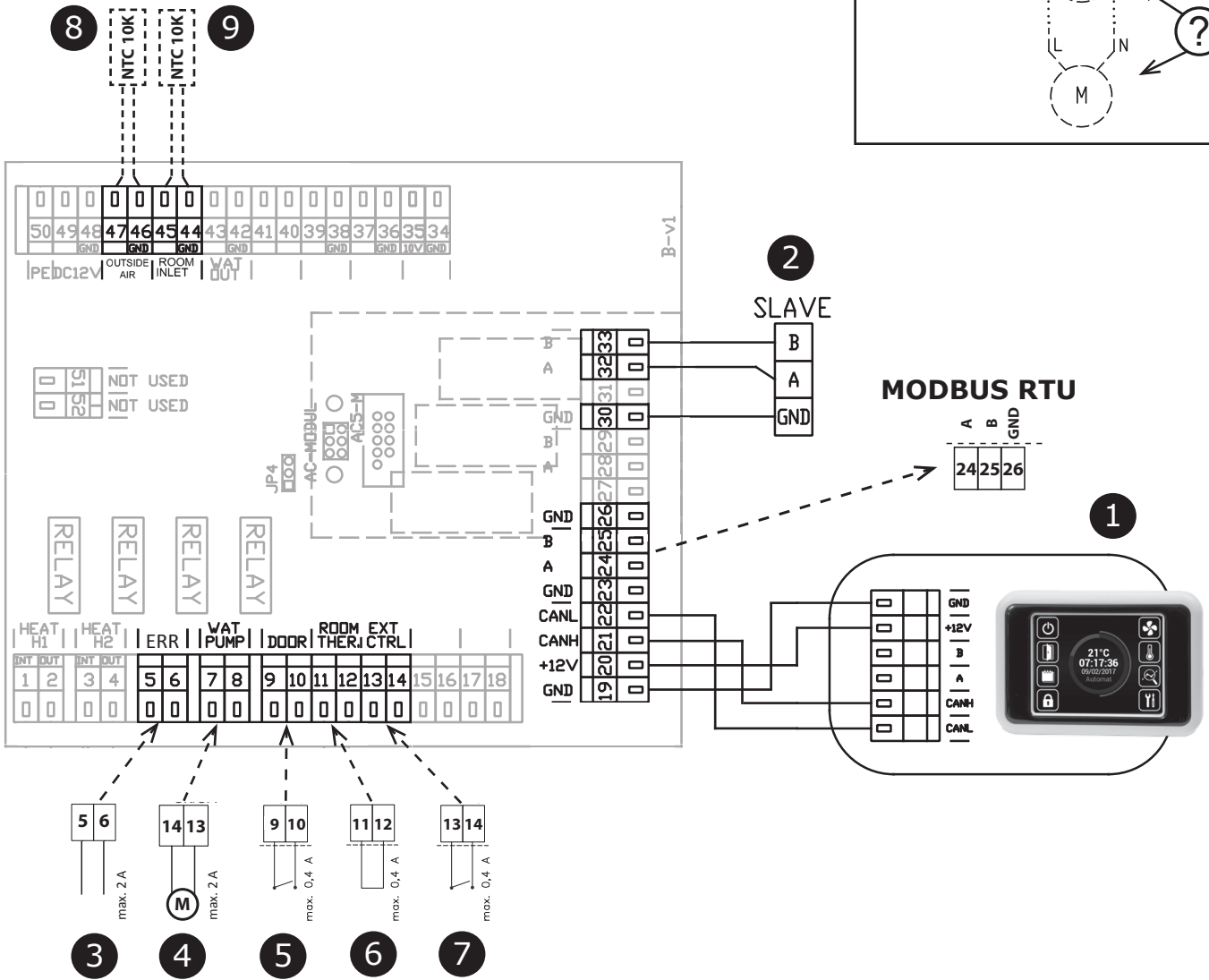
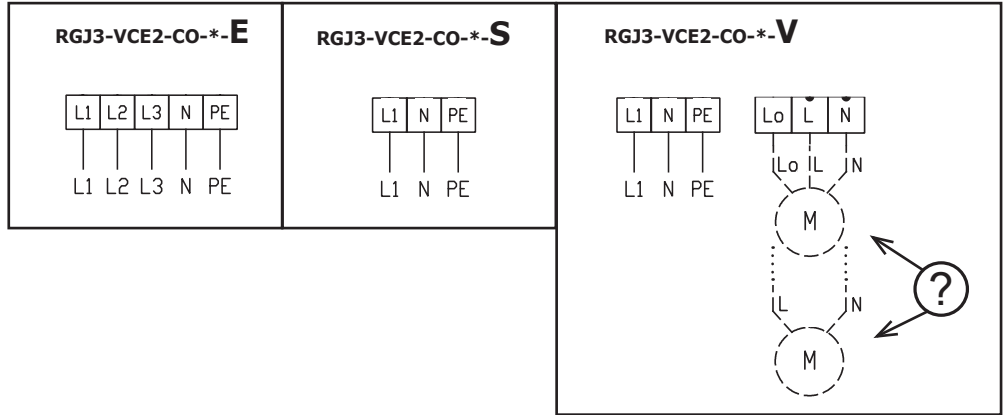

	EN	DE
1	Control panel	Bedienelement
2	Signal to SLAVE unit	Signal zur SLAVE Anlage
3	ERROR contact (relay contact, NO/NC)	ERROR-kontakt (Relaiskontakt, NO/NC)
4	Water pump (relay contact)	Wasserpumpe (Relaiskontakt)
5	DOOR contact (input, NO/NC)	Türkontakt (Eingang, NO/NC)
6	Room thermostat (input, NO/NC)	Raumthermostat (Eingang, NO/NC)
7	External control (input, NO/NC)	Externe Steuerung (Eingang, NO/NC)
8	Outside air temp. sensor (include delivery)	Außenlufttemperatur Sensor (im Lieferumfang enthalten)
9	Room temp. sensor (include delivery)	Raumtemperatur. Sensor (im Lieferumfang enthalten)



WIRING DIAGRAMS



SCHALTPLÄNE



AirGENIO COMFORT
SLAVE

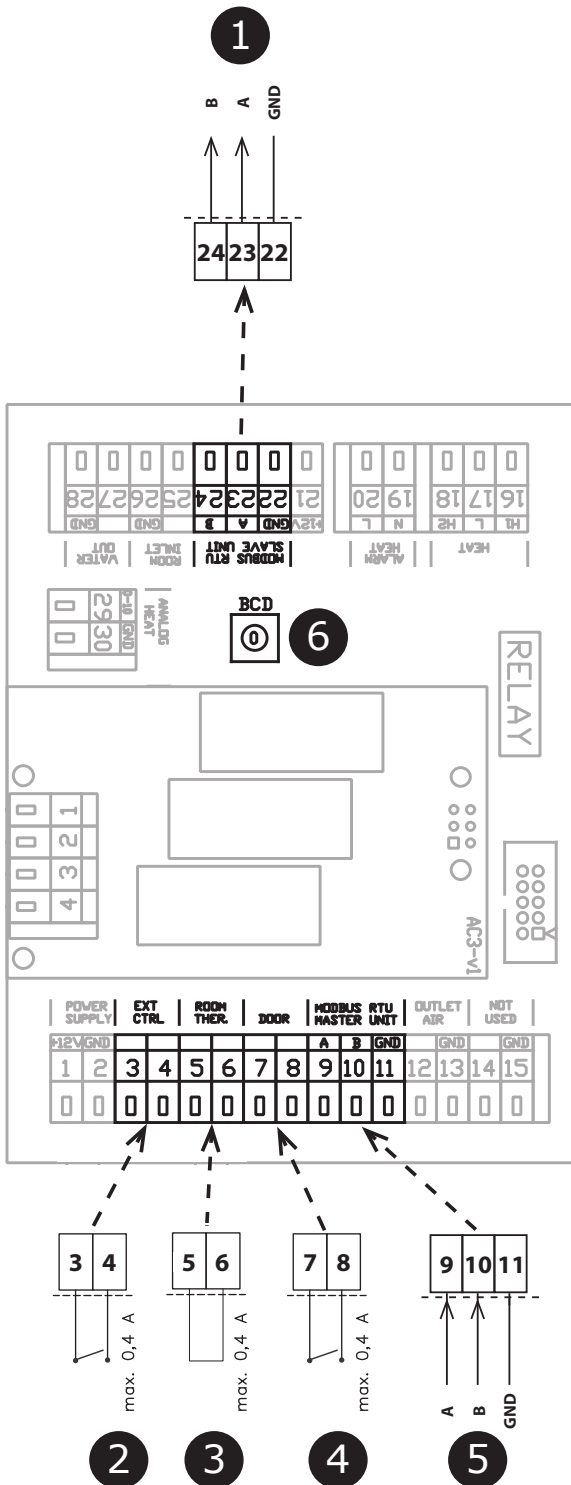
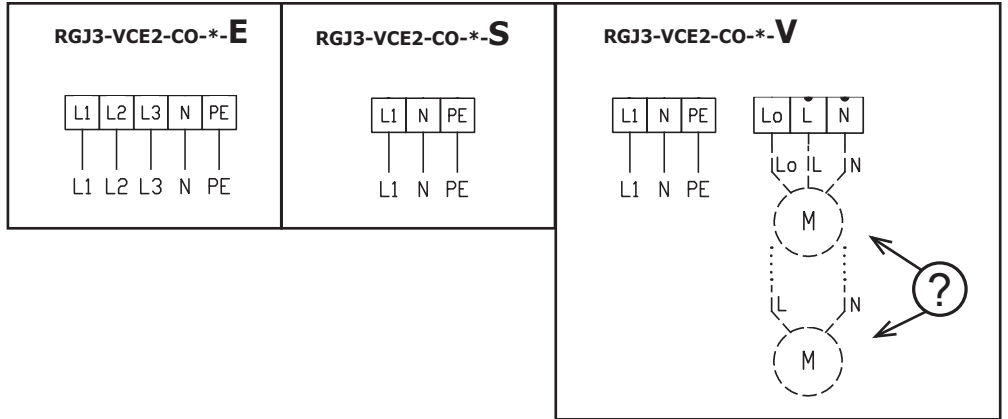

EN	
1	Signal to SLAVE unit
2	External control - ON/OFF
3	Room thermostat (input)
4	DOOR contact (input)
5	Signal from MASTER unit

DE	
1	Signal zur SLAVE Anlage
2	Externe Steuerung - AN/AUS
3	Raumthermostat (Eingang)
4	Türkontakt (Eingang)
5	Signal aus der MASTER Anlage

6

SLAVE	BCD
1	1
2	2
3	3
4	4
5	5
6	6
7	7
8	8
9	9
10	A

WIRING DIAGRAMS

SCHALTPLÄNE



AirGENIO SUPERIOR MASTER

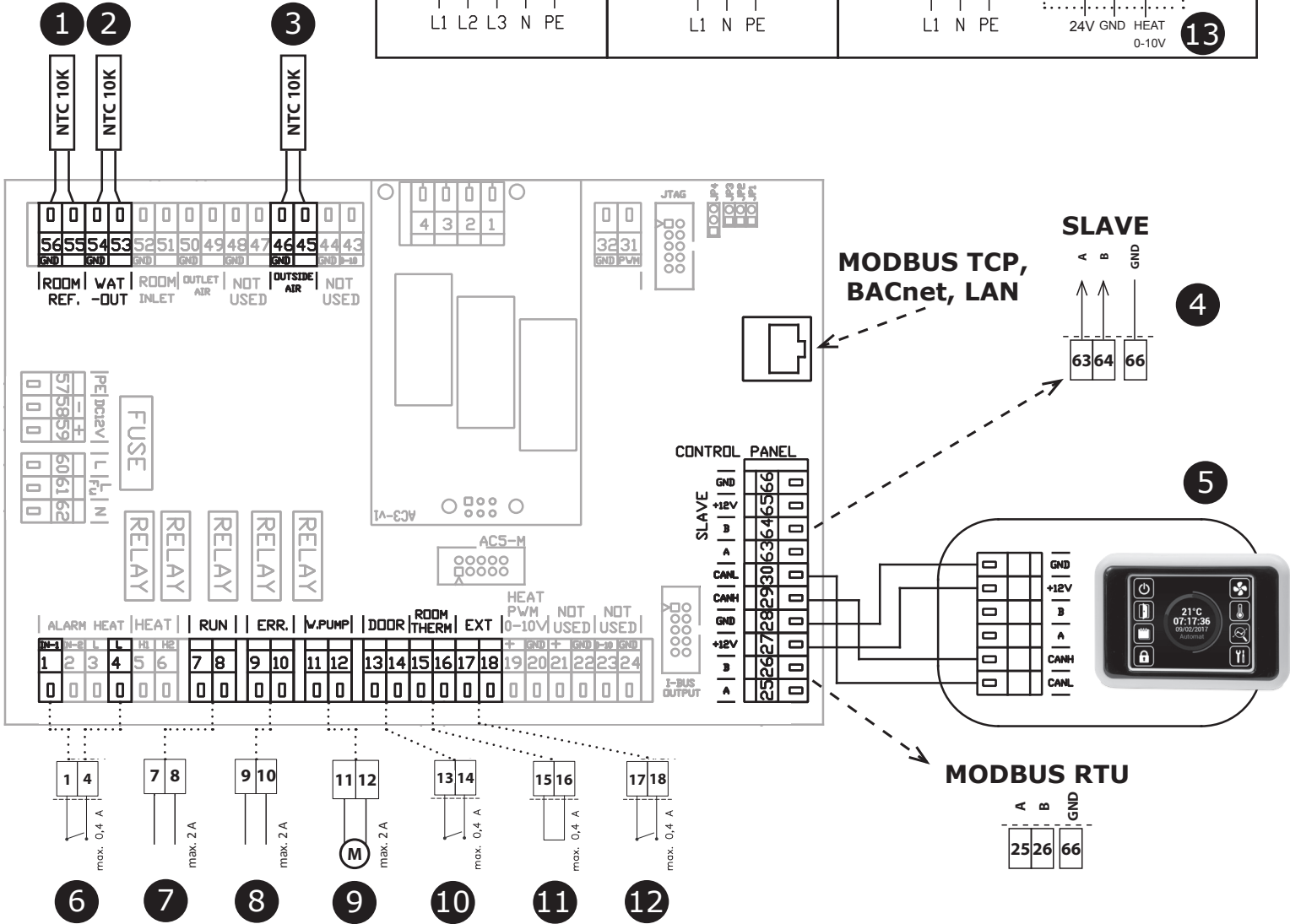
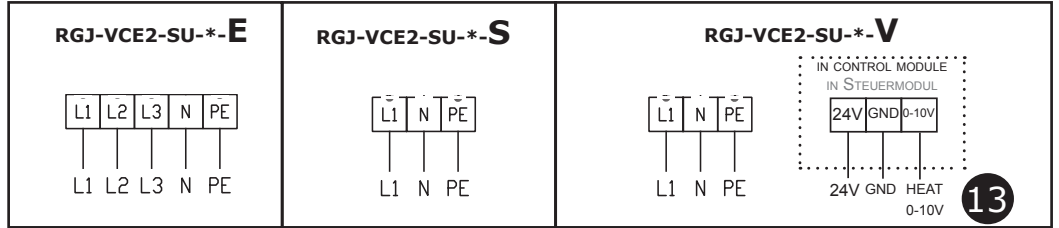

	EN	DE
1	Room sensor (accessories)	Raumsensor (Zubehör)
2	LPHW out sensor (included in delivery)	Wasserausgangssensor (Im Lieferumfang enthalten)
3	Outside air sensor (included in delivery)	Außenlufttemperatursensor (Im Lieferumfang enthalten)
4	Signal to SLAVE unit	Signal zur SLAVE Anlage
5	Control panel	Bedienelement
6	Antifreeze thermostat (NC)	Frostschuttfühler (NC)
7	RUN contact (relay contact, NO/NC)	RUN-kontakt (Relaiskontakt, NO/NC)
8	ERROR contact (relay contact, NO/NC)	ERROR-kontakt (Relaiskontakt, NO/NC)
9	Water pump (relay contact)	Wasserpumpe (Relaiscontact)
10	DOOR contact (input, NO/NC)	Türkontakt (Eingang, NO/NC)
11	Room thermostat (input, NO/NC)	Raumthermostat (Eingang, NO/NC)
12	External control (input, NO/NC)	Externe Steuerung (Eingang, NO/NC)
13	Water valve control (0-10V)	Wasserventil (0-10V)

WIRING DIAGRAMS

SCHALTPLÄNE



AirGENIO SUPERIOR
SLAVE

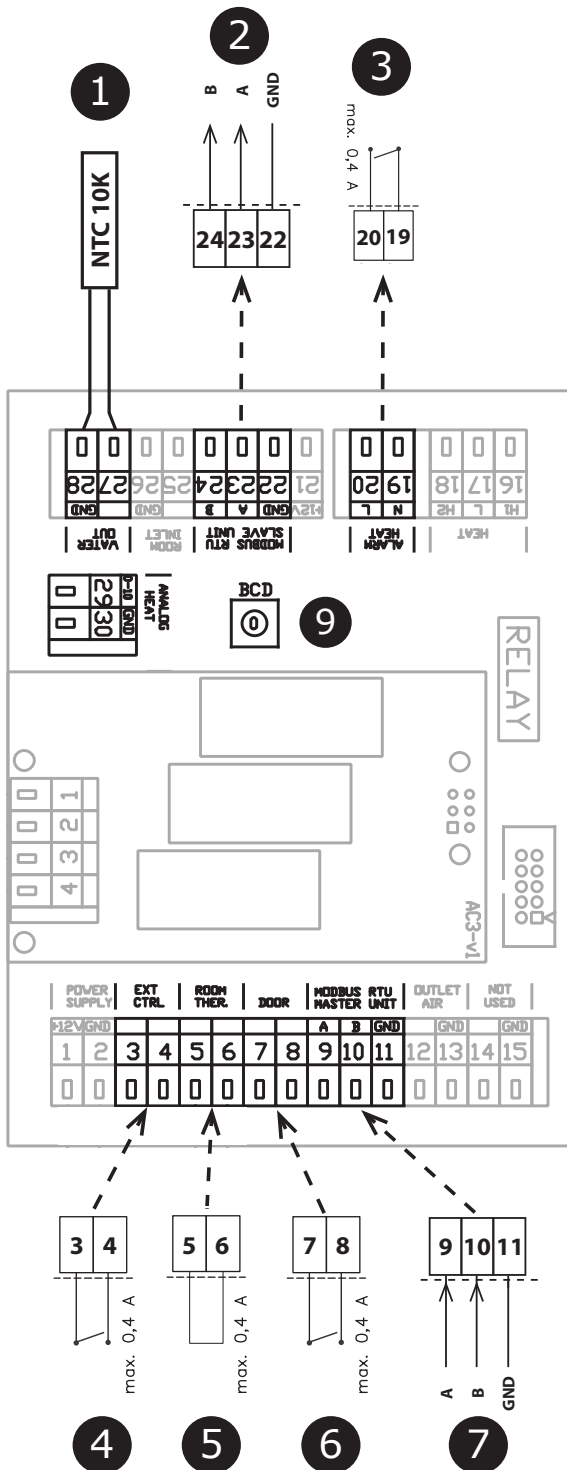
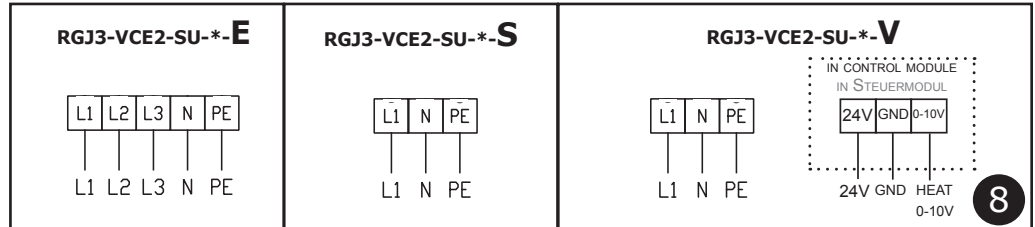

EN	
1	LPHW out sensor (included in delivery)
2	Signal to SLAVE unit
3	Antifreeze thermostat (NC)
4	External control - ON/OFF
5	Room thermostat (input)
6	DOOR contact (input)
7	Signal from MASTER unit
8	Water valve control (0-10V)

DE	
1	Wasserausgangssensor (Im Lieferumfang enthalten)
2	Signal zur SLAVE Anlage
3	Frostschutzfühler (NC)
4	Externe Steuerung - AN/AUS
5	Raumthermostat (Eingang)
6	Türkontakt (Eingang)
7	Signal aus der MASTER Anlage
8	Wasserventil (0-10V)

9

SLAVE	BCD
1	1
2	2
3	3
4	4
5	5
6	6
7	7
8	8
9	9
10	A



WIRING DIAGRAMS
Chaining



SCHALTPLÄNE
Verkettungs

AirGENIO SUPERIOR

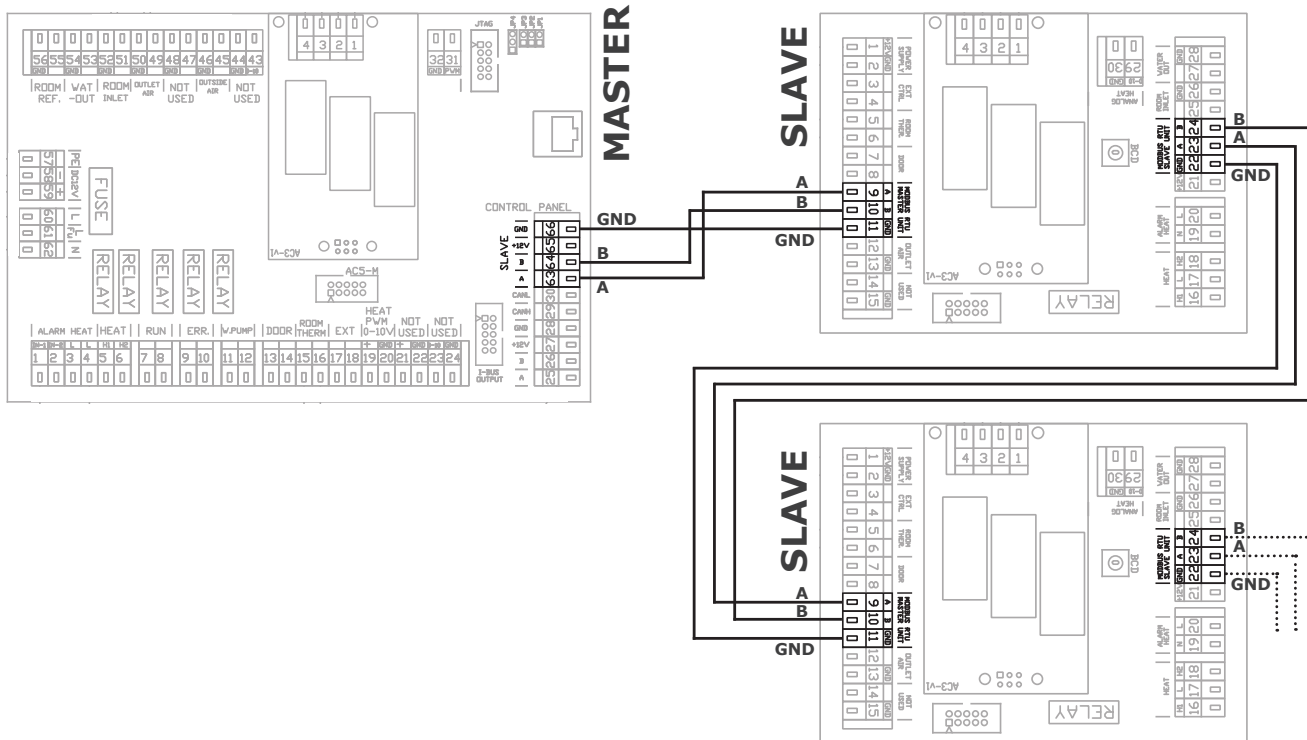

AirGENIO COMFORT

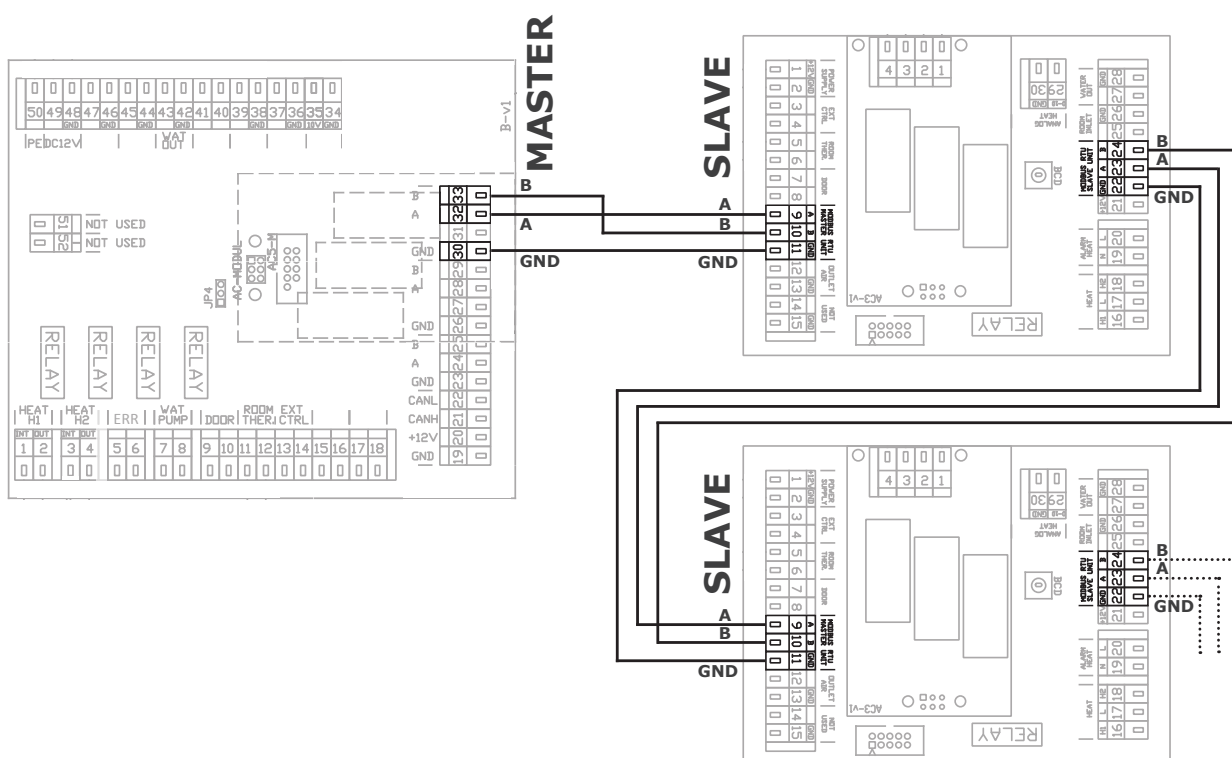

Chaining

Verkettungs

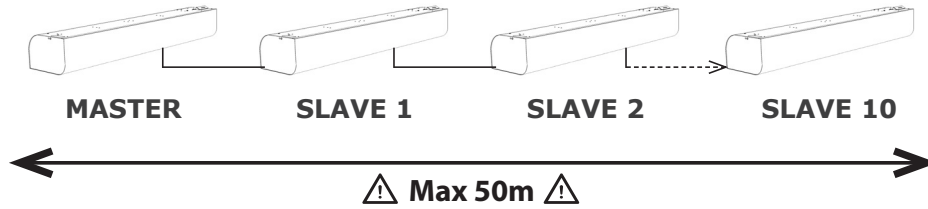

KEY TO CODING

CODIERSCHLÜSSEL

- VCES2 B 100-E0 AC-CR-0 A0**
- A0** - 2VV version
 - 9** - Atyp RAL
 - 0** - Standard RAL
 - CR** - Control ready
 - AC** - AC motor
 - E0** - Electric heater with reduced power (*only for B range*)
 - E1** - Electric heater (Standard)
 - E2** - Electric heater with increased power (*only for B range*)
 - V2** - Water heater
 - S0** - Air-only (ambient)
 - 100** - Nominal width 1000 mm
 - 150** - Nominal width 1500 mm
 - 200** - Nominal width 2000 mm
 - 250** - Nominal width 2500 mm
 - B** - Output series
 - C** - Output series
 - VCES2** - Air Curtain ESSENSSE NEO

- VCES2 B 100-E0 AC-CR-0 A0**
- A0** - 2VV Variante
 - 9** - Atyp RAL
 - 0** - Standard RAL
 - CR** - Steuerung bereit
 - AC** - AC Lüfter
 - E0** - Elektrowärmetauscher mit Minderleistung (*nur für B-Out-put-Serie*)
 - E1** - Elektrowärmetauscher (Standard)
 - E2** - Elektrowärmetauscher mit erhöhter Leistung (*nur für B-Out-put-Serie*)
 - V2** - Wasserwärmetauscher
 - S0** - ohne Wärmetauscher
 - 100** - Nominale Länge 1000 mm
 - 150** - Nominale Länge 1500 mm
 - 200** - Nominale Länge 2000 mm
 - 250** - Nominale Länge 2500 mm
 - B** - Output-Serie
 - C** - Output-Serie
 - VCES2** - Luftschleier ESSENSSE NEO